

Dimensions: RGS1S

RGS1S60D20GKEP, RGS1S60D30GKEP, RGS1S60D31GKEP

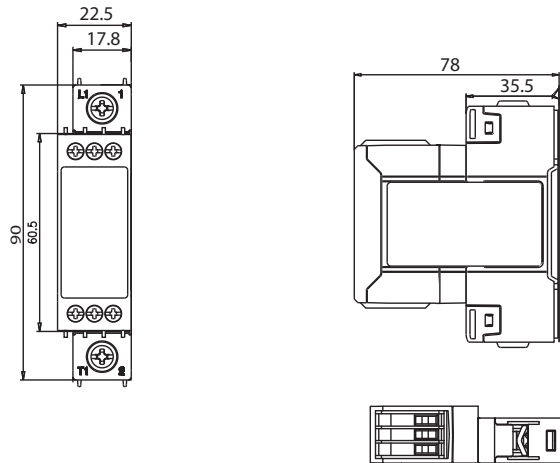

RGS1S60D61GGEP

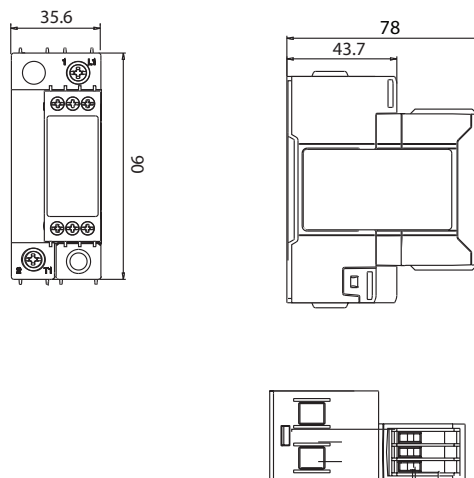

RGS1S60D61GGUP

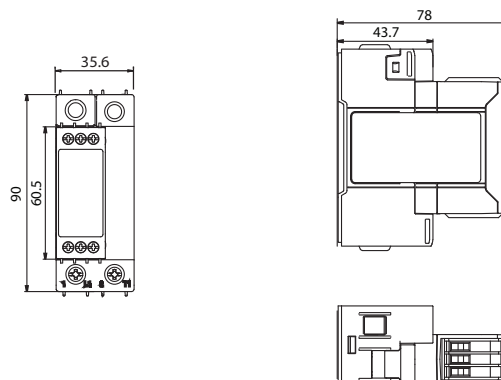

Housing width tolerance +0.5mm, -0mm...as per DIN43880
 All other tolerances: $\pm 0.5\text{mm}$
 All dimensions in mm

Dimensions: RGC1S

RGC1S60D20GKEP

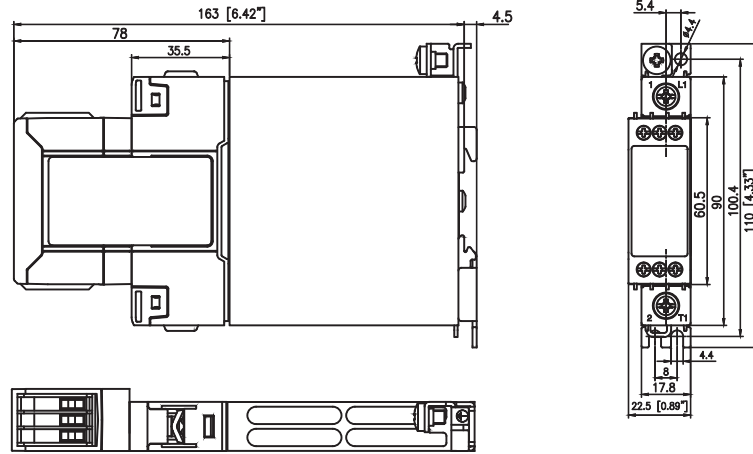

RGC1S60D25GKEP

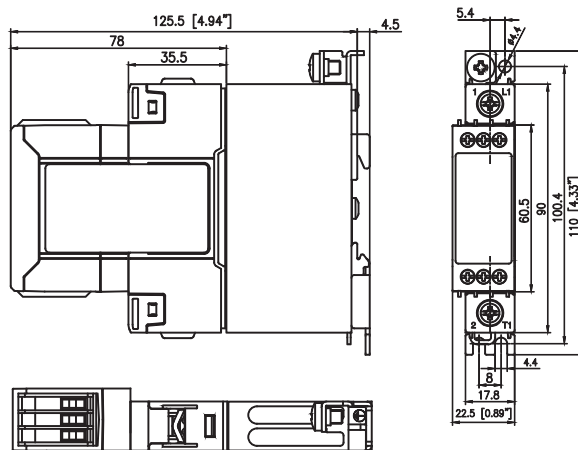

RGC1S60D30GKEP , RGC1S60D31GKEP

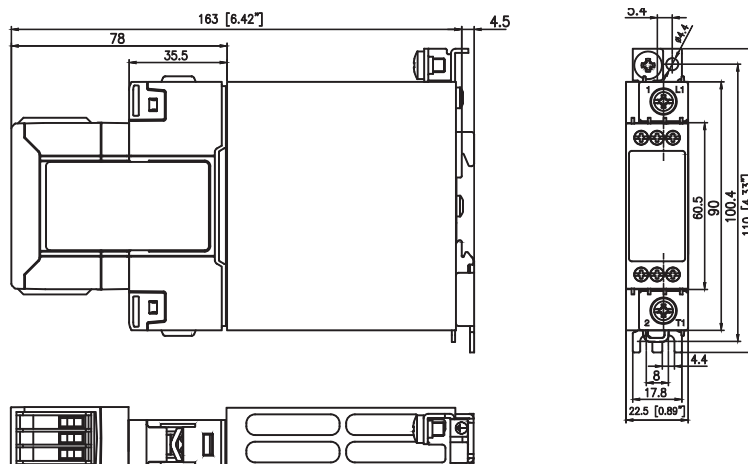

Housing width tolerance +0.5mm, -0mm...as per DIN43880
 All other tolerances: ± 0.5 mm
 All dimensions in mm

Dimensions: RGC1S

RGC1S60D41GGEP

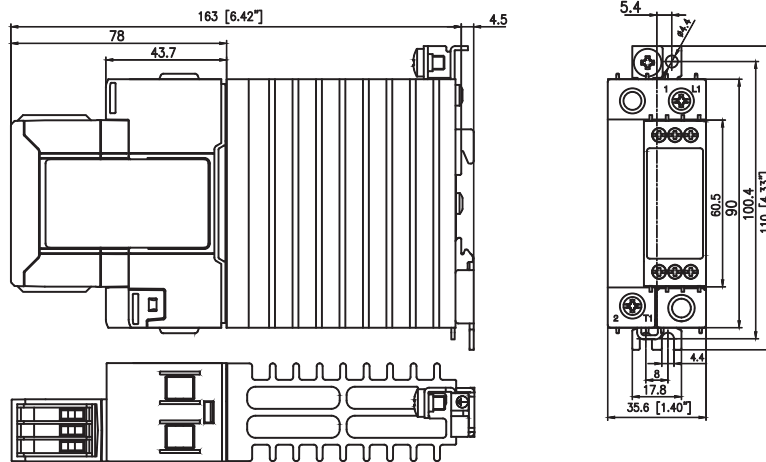

RGC1S60D61GGEP

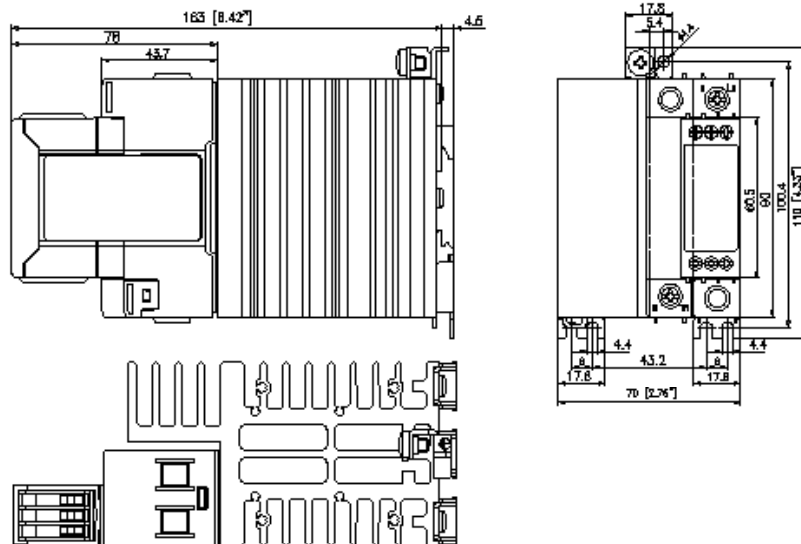

RGC1S60D90GGEP

(fan to be supplied externally - no terminations provided on the RG module)

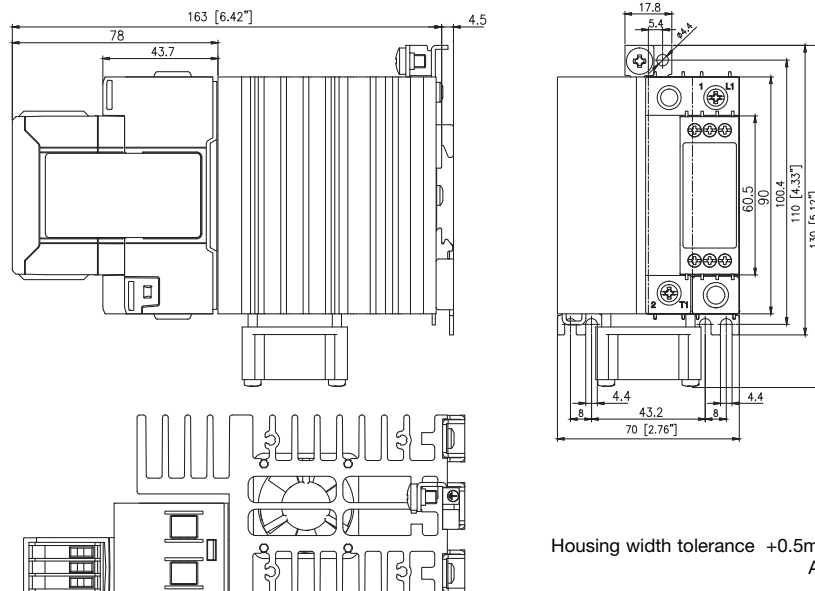

Housing width tolerance +0.5mm, -0mm...as per DIN43880
 All other tolerances: ± 0.5mm
 All dimensions in mm

Dimensions: RGC1S

RGC1S60D41GGUP

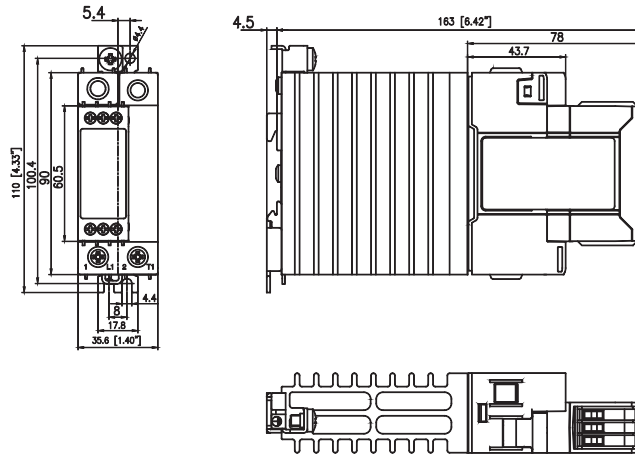

RGC1S60D61GGUP

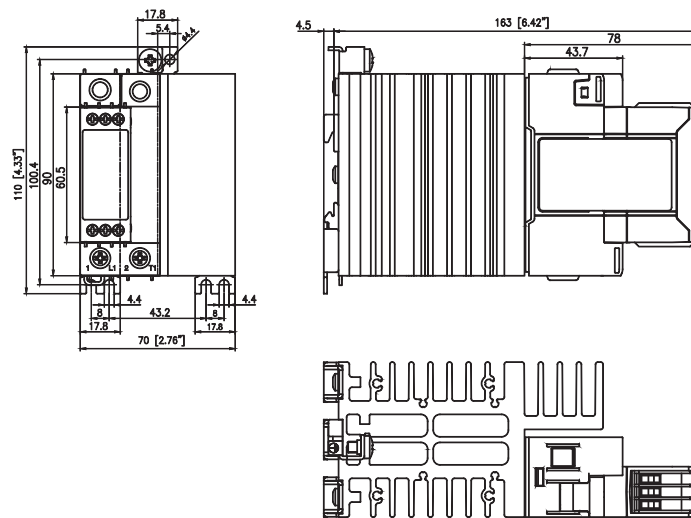

Housing width tolerance +0.5mm, -0mm...as per DIN43880
 All other tolerances: $\pm 0.5\text{mm}$
 All dimensions in mm